

Title: Solar Power Bank		Code: DFR1191	
Drawn: Roker-CD	Revision: V1.0.0	Size: A4	
Page: 1 of 4	Date: 2024/12/5	Time: 9:38:06	

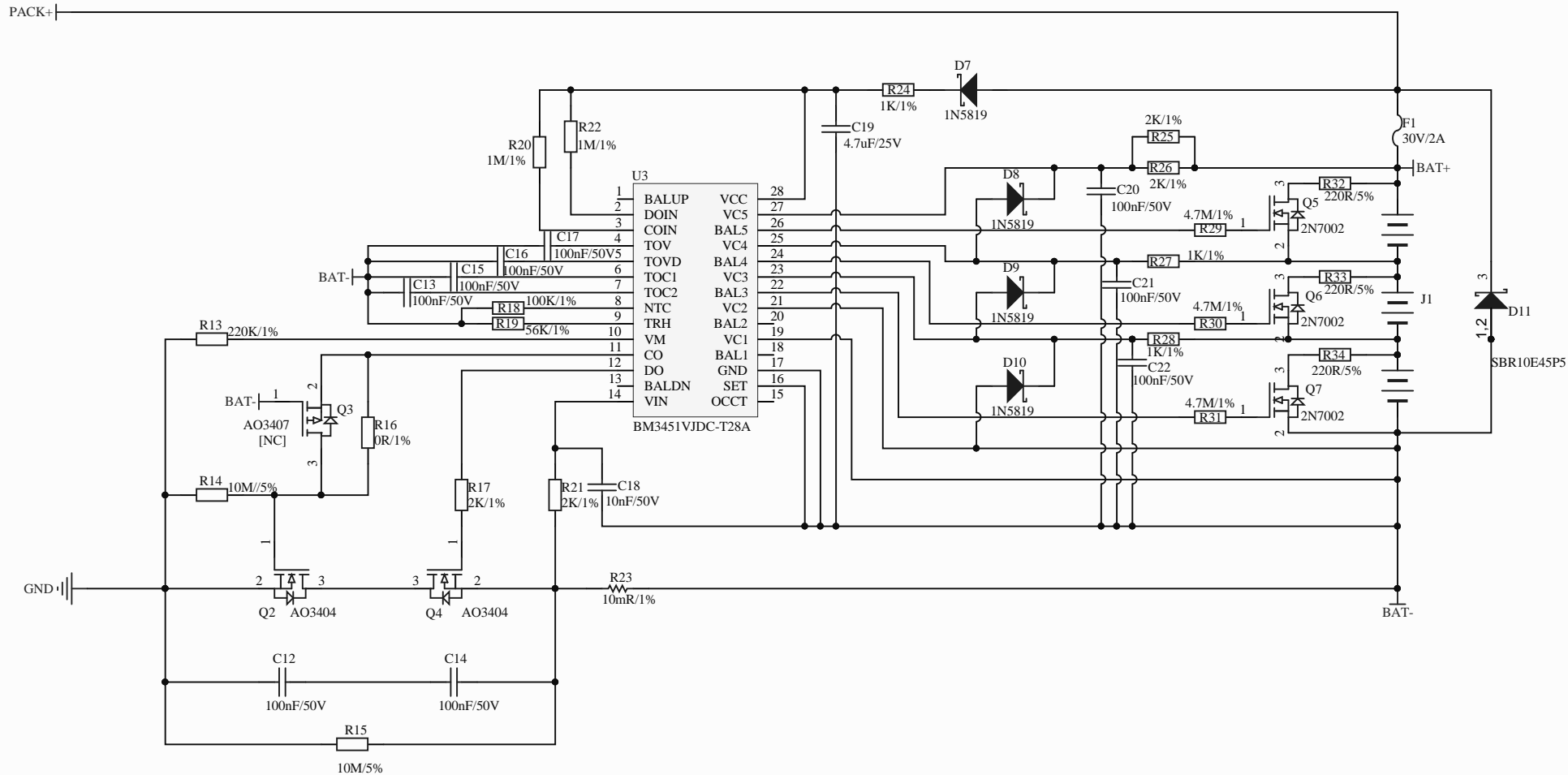

Title: Solar Power Bank	Code: DFRI191
Drawn: Roker-CD	Revision: V1.0.0
Page: 2 of 4	Size: A4
Date: 2024/12/5	Time: 9:38:06

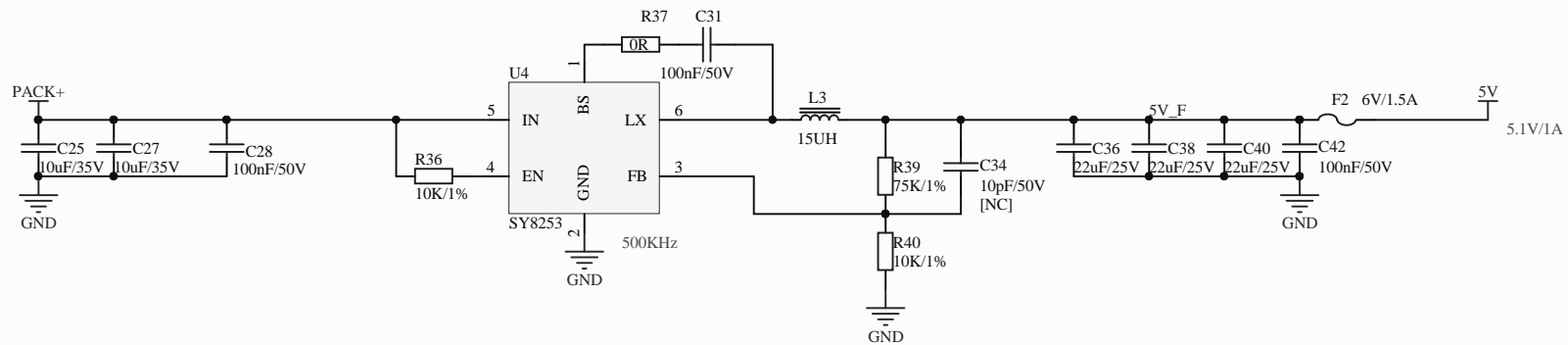
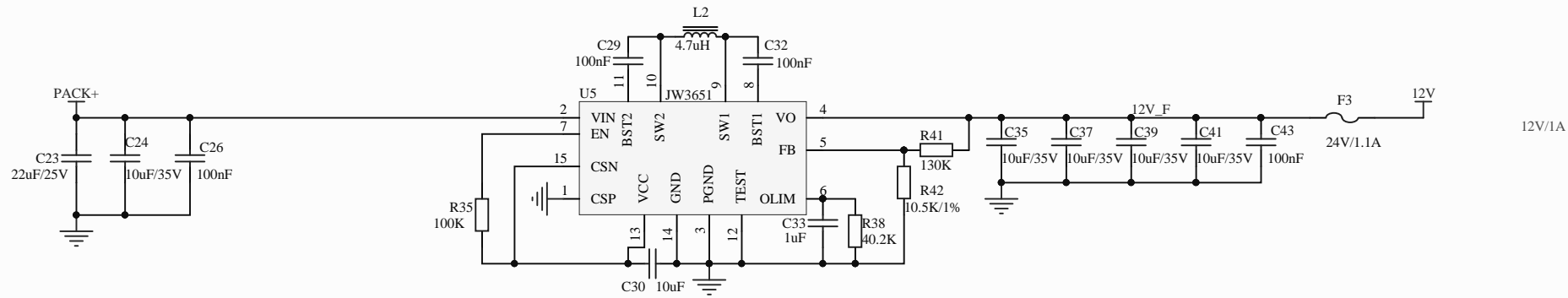

Title: Solar Power Bank	Code: DFRI191
Drawn: Roker-CD	Revision: V1.0.0
Page: 3 of 4	Size: A4
Date: 2024/12/5	Time: 9:38:06

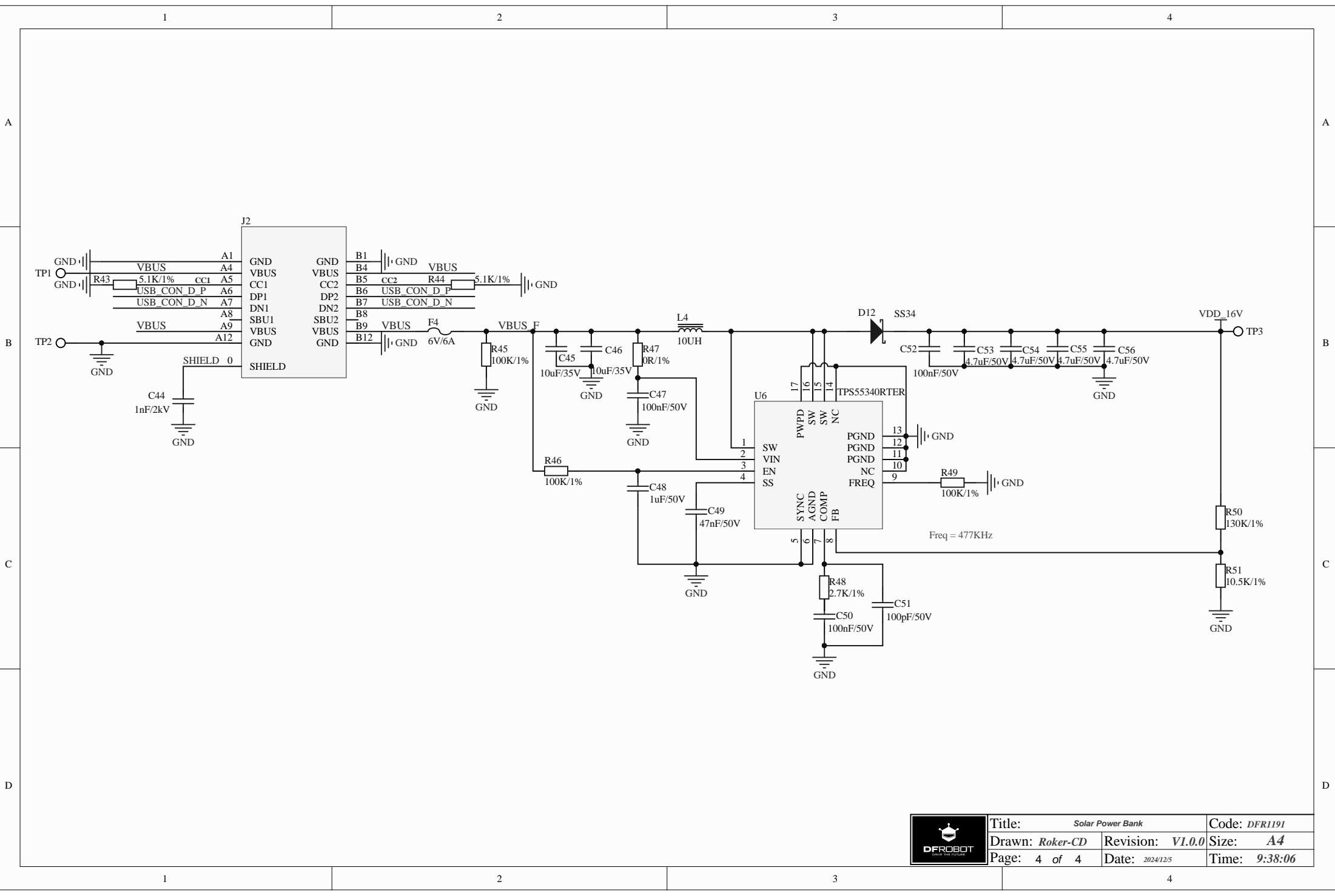

Title:	Solar Power Bank	Code:	DFR1191
Drawn:	Roker-CD	Revision:	V1.0.0
Page:	4 of 4	Date:	2024/12/5
		Size:	A4
		Time:	9:38:06

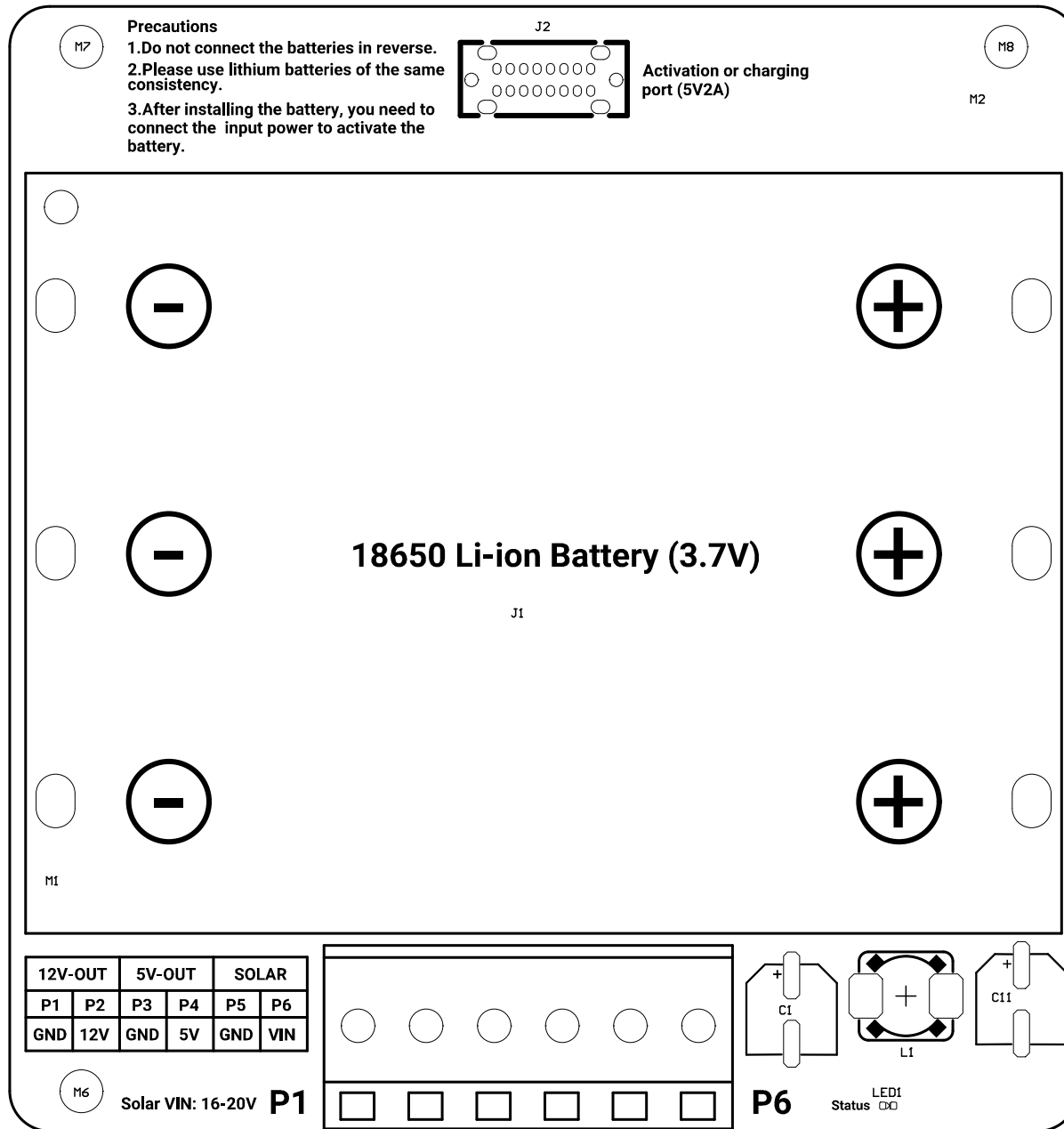

P1

PCB Information		Name:DFR1191[V1.0.0]	Thickness: 1.6mm
Engineer:Roker_CD	Top SolderMask: Black	Bottom SolderMask: Black	
Date:20241204	Top Silkscreen: White	Bottom Silkscreen: White	

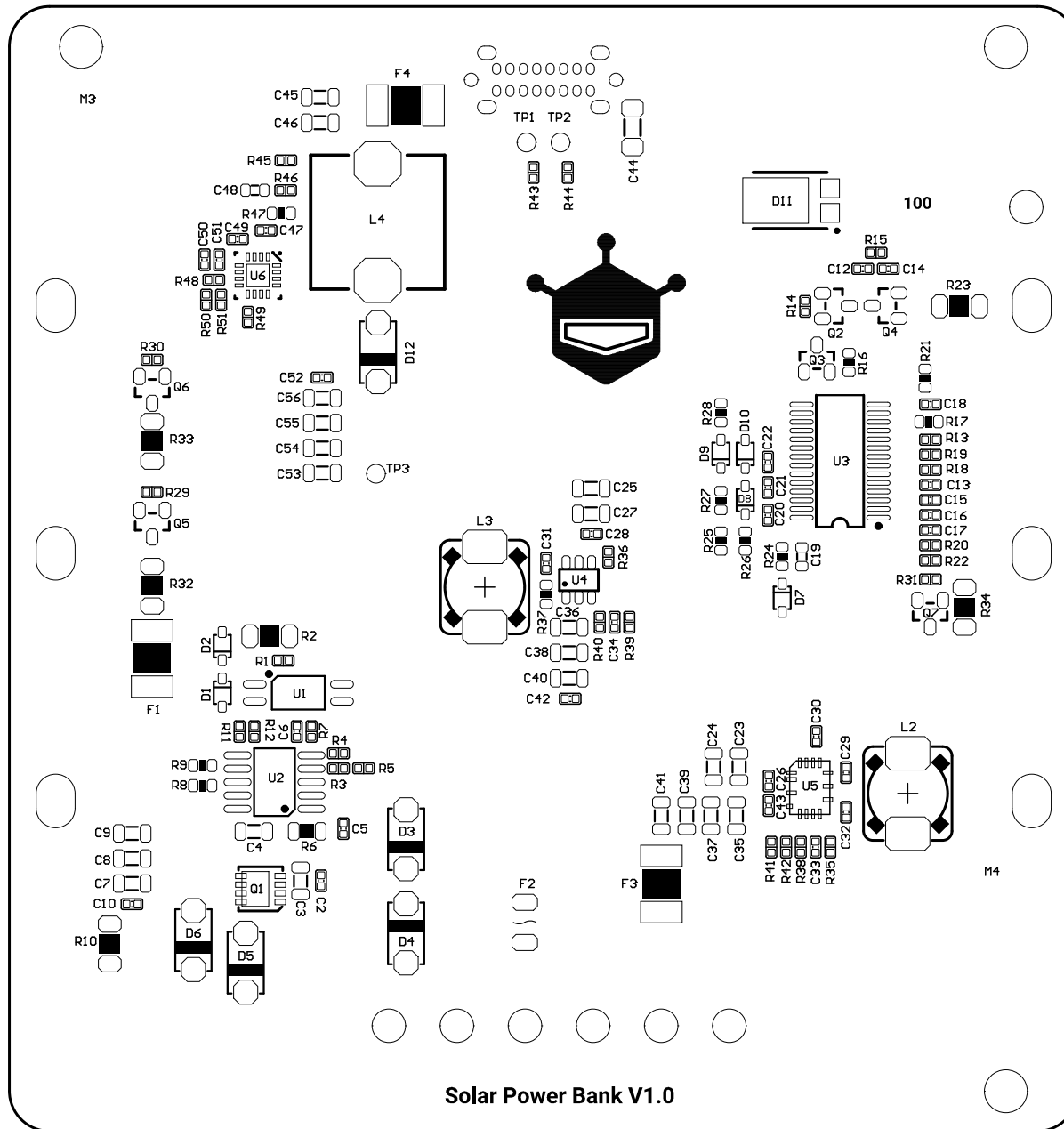

PCB Information	Name:DFR1191[V1.0.0]	Thickness: 1.6mm
Engineer:Roker_CD	Top SolderMask: Black	Bottom SolderMask: Black
Date:20241204	Top Silkscreen: White	Bottom Silkscreen: White

